

BY 098

Capacity: 3.2 t
 Hoisting height: 3.2 m
 Reeving: 1/1
 Working rate group FEM 9.511: 1Am
 Working rate group ISO: M4
 Hoisting speed: 5 m/min
 Traveling speed: 20 m/min
 Electric motor for hoisting: 4.5 kW
 Electric motor for traveling: 0.25 kW
 "I" profile width: 130÷150 mm
 Chain: 13x36 mm

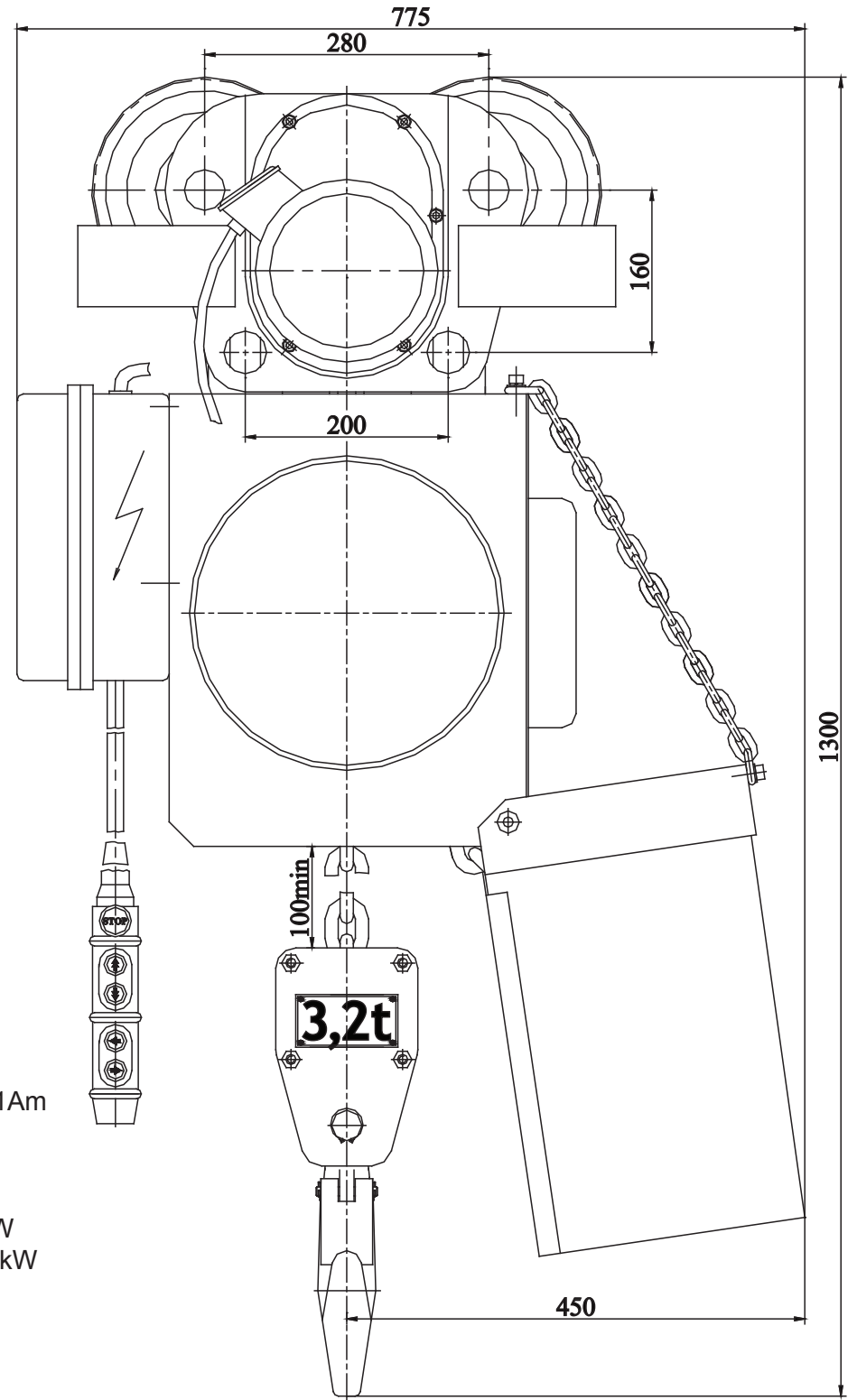

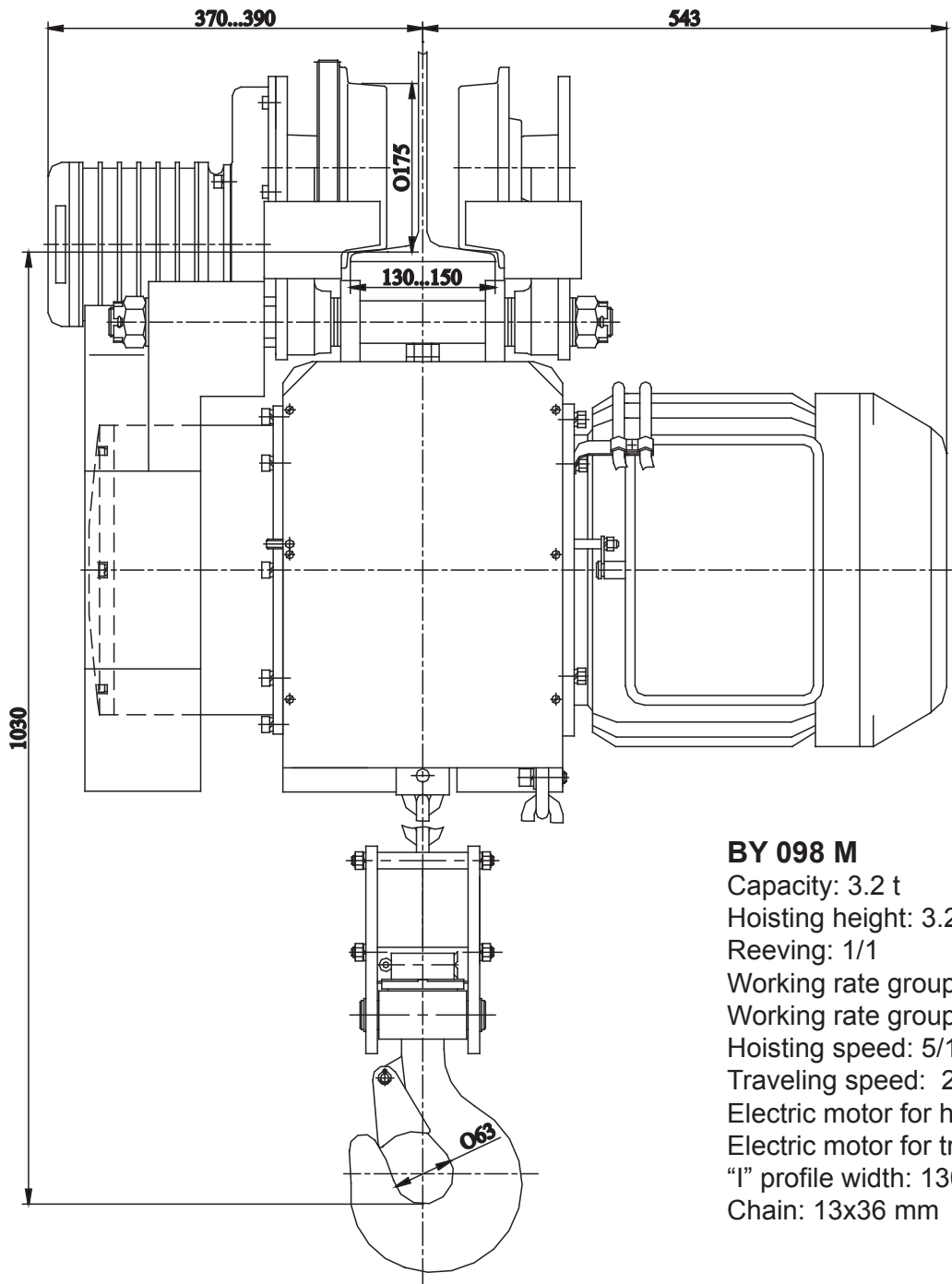

BY 098 M

Capacity: 3.2 t

Hoisting height: 3.2 m

Reeving: 1/1

Working rate group FEM 9.511: 1Am

Working rate group ISO: M4

Hoisting speed: 5/1.04 m/min

Traveling speed: 20 m/min

Electric motor for hoisting: 4.8/1.0 kW

Electric motor for traveling: 0.25 kW

"I" profile width: 130÷150 mm

Chain: 13x36 mm

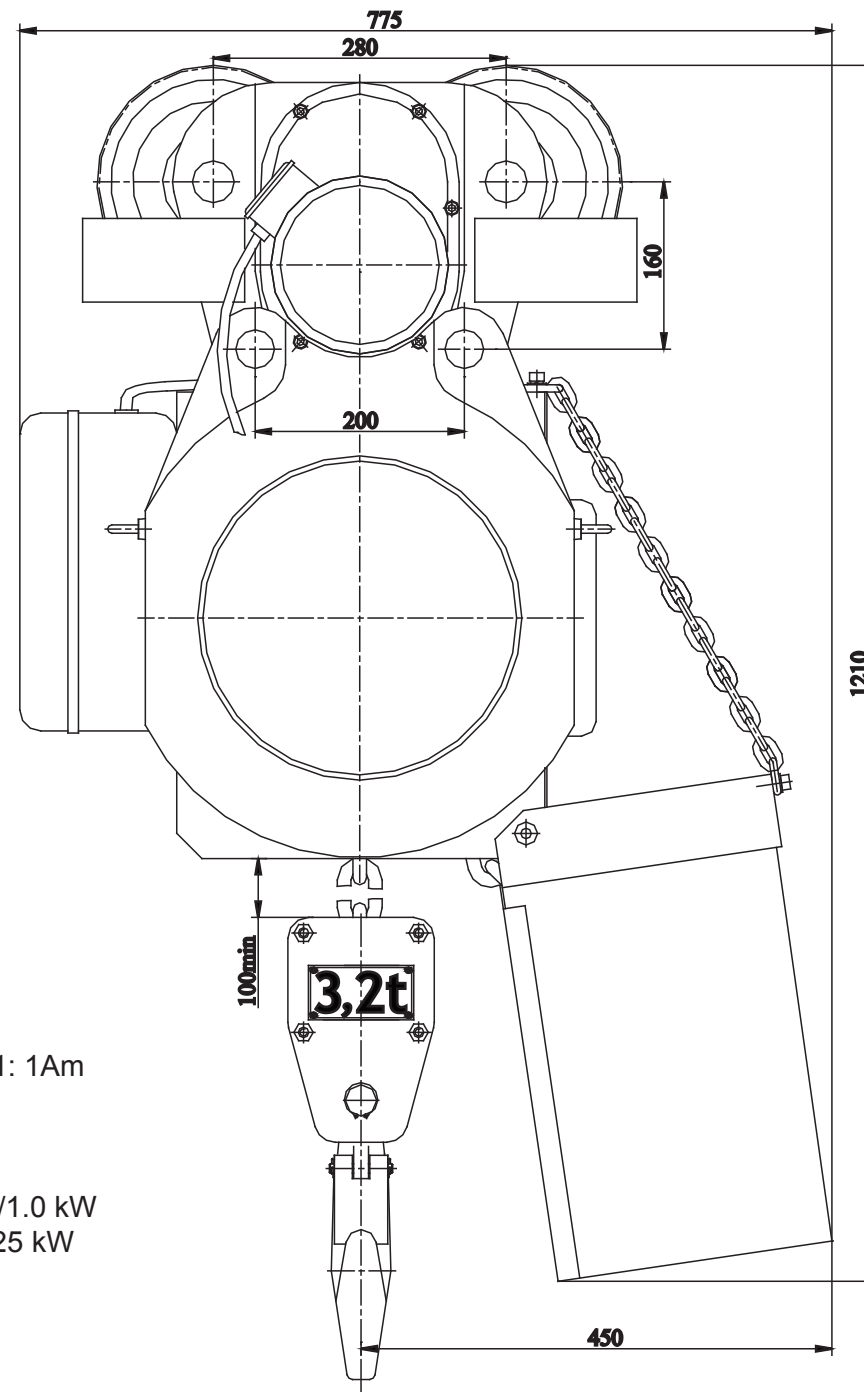

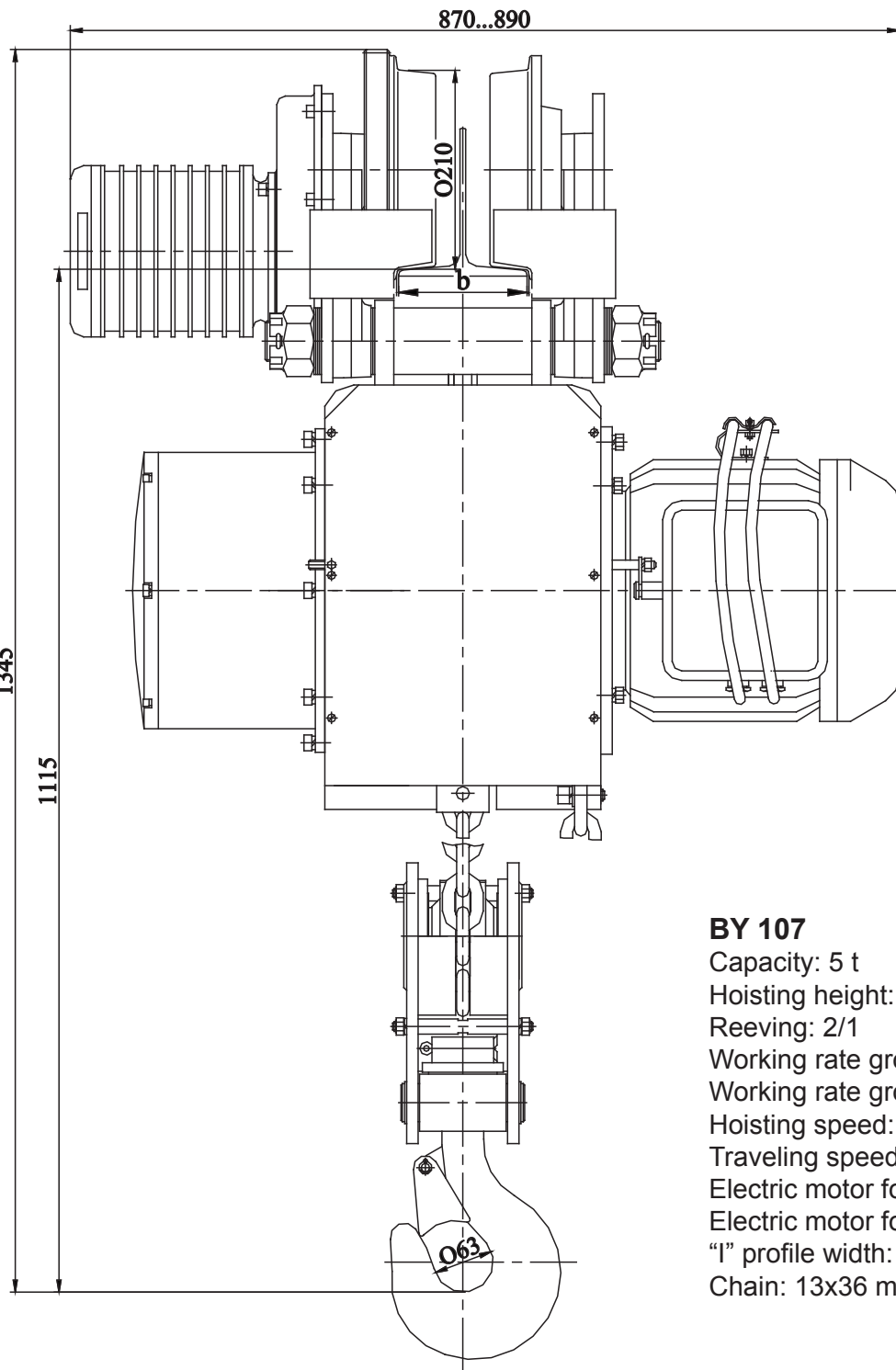

BY 107

Capacity: 5 t

Hoisting height: 3.2 m

Reeving: 2/1

Working rate group FEM 9.511: 1Am

Working rate group ISO: M4

Hoisting speed: 4 m/min

Traveling speed: 20 m/min

Electric motor for hoisting: 4.5 kW

Electric motor for traveling: 0.37 kW

"I" profile width: 130÷150 mm

Chain: 13x36 mm

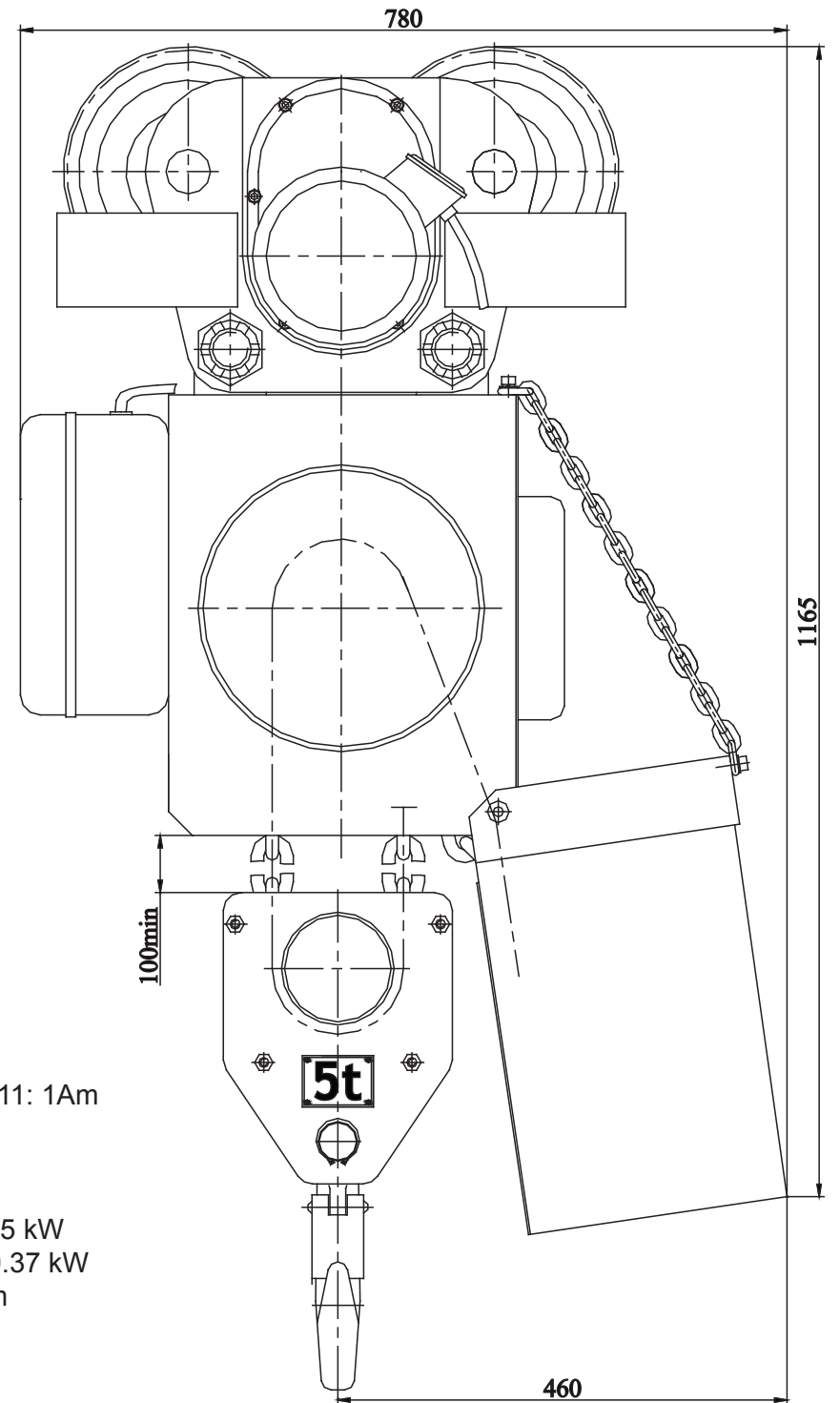

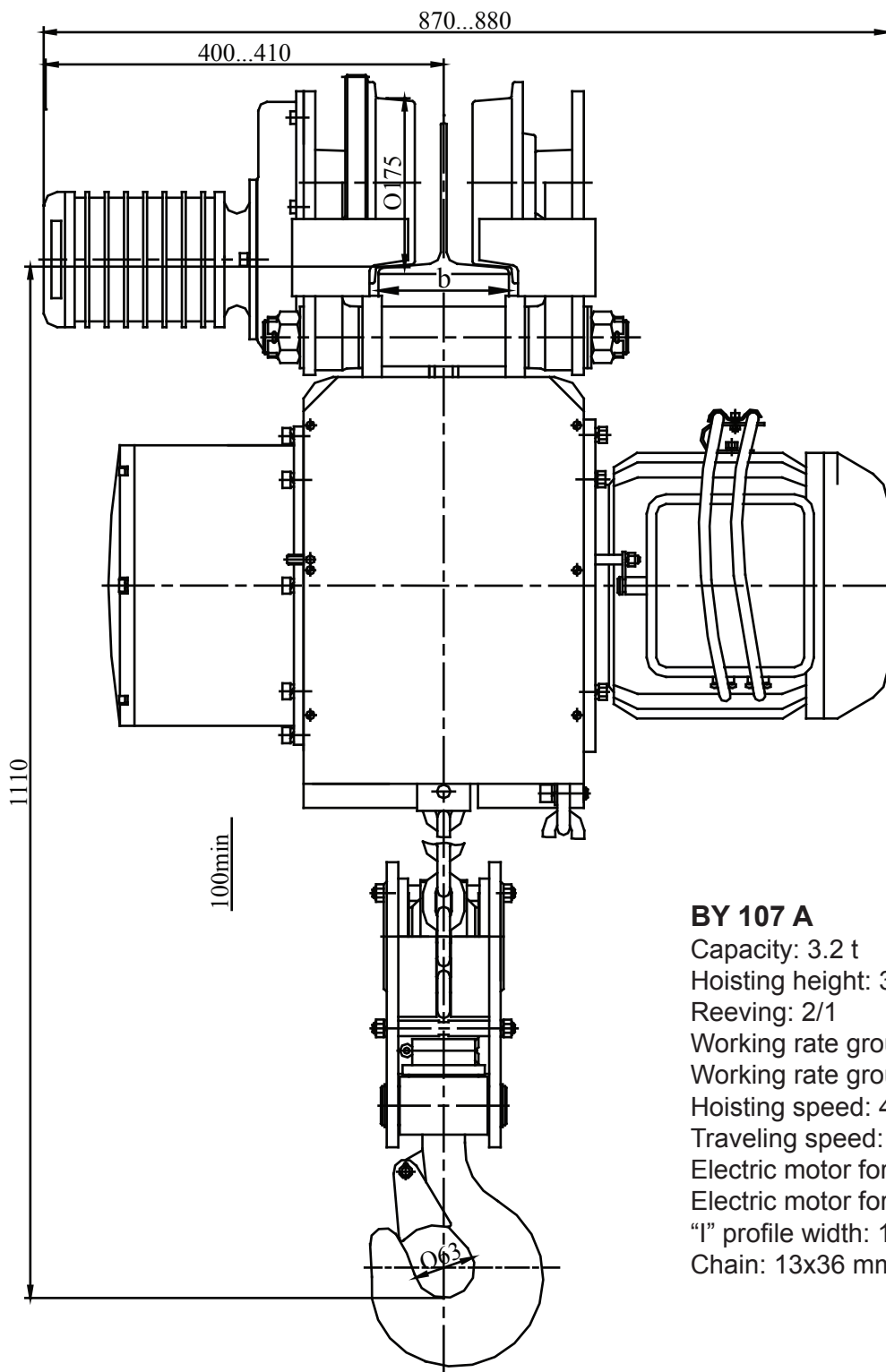

BY 107 A

Capacity: 3.2 t

Hoisting height: 3.2 m

Reeving: 2/1

Working rate group FEM 9.511: 1Am

Working rate group ISO: M4

Hoisting speed: 4 m/min

Traveling speed: 20 m/min

Electric motor for hoisting: 3 kW

Electric motor for traveling: 0.44 kW

"I" profile width: 130±150 mm

Chain: 13x36 mm

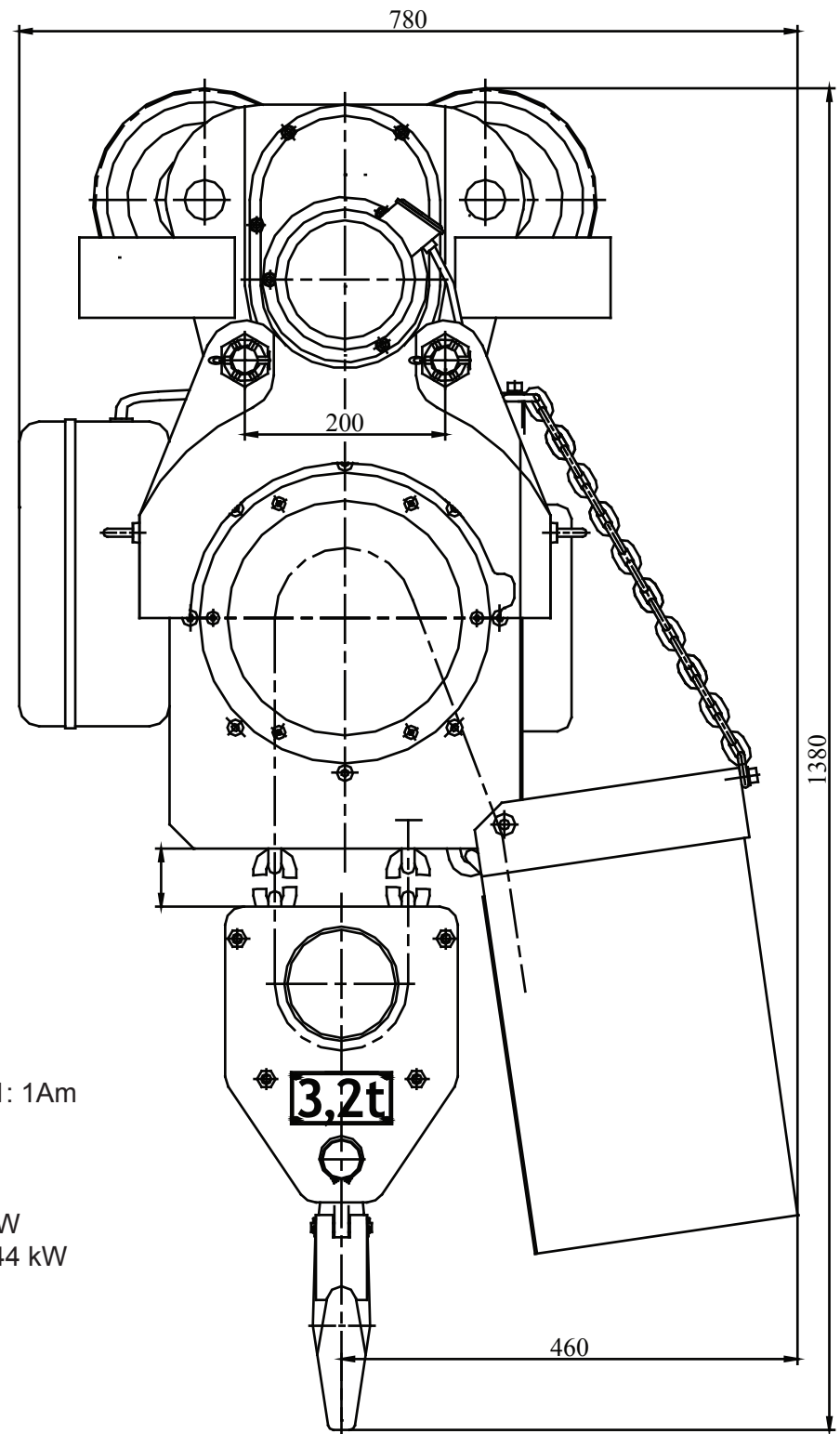

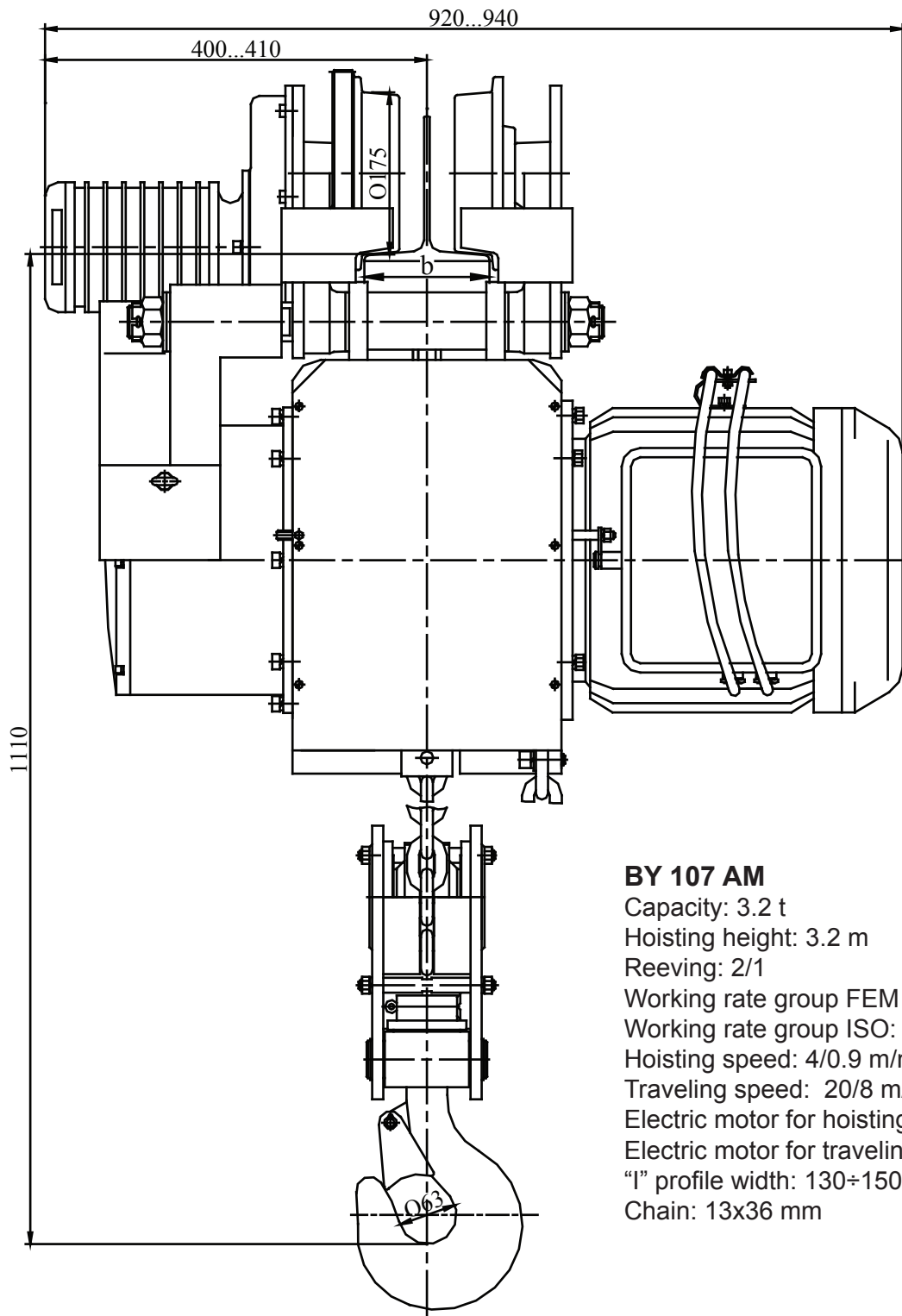

BY 107 AM

Capacity: 3.2 t

Hoisting height: 3.2 m

Reeving: 2/1

Working rate group FEM 9.511: 1Am

Working rate group ISO: M4

Hoisting speed: 4/0.9 m/min

Traveling speed: 20/8 m/min

Electric motor for hoisting: 3/0.7 kW

Electric motor for traveling: 0.44/0.12 kW

"I" profile width: 130÷150 mm

Chain: 13x36 mm

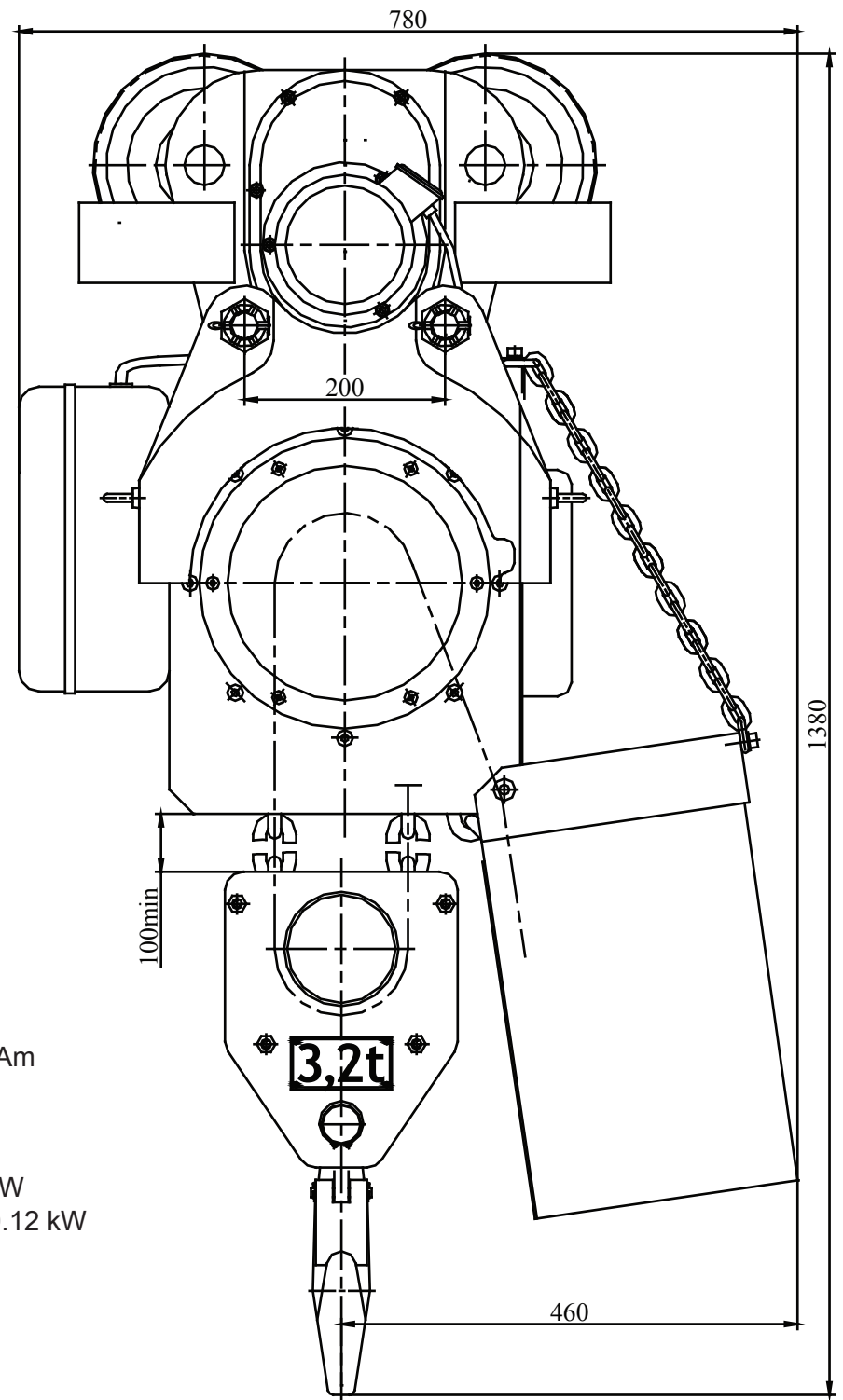

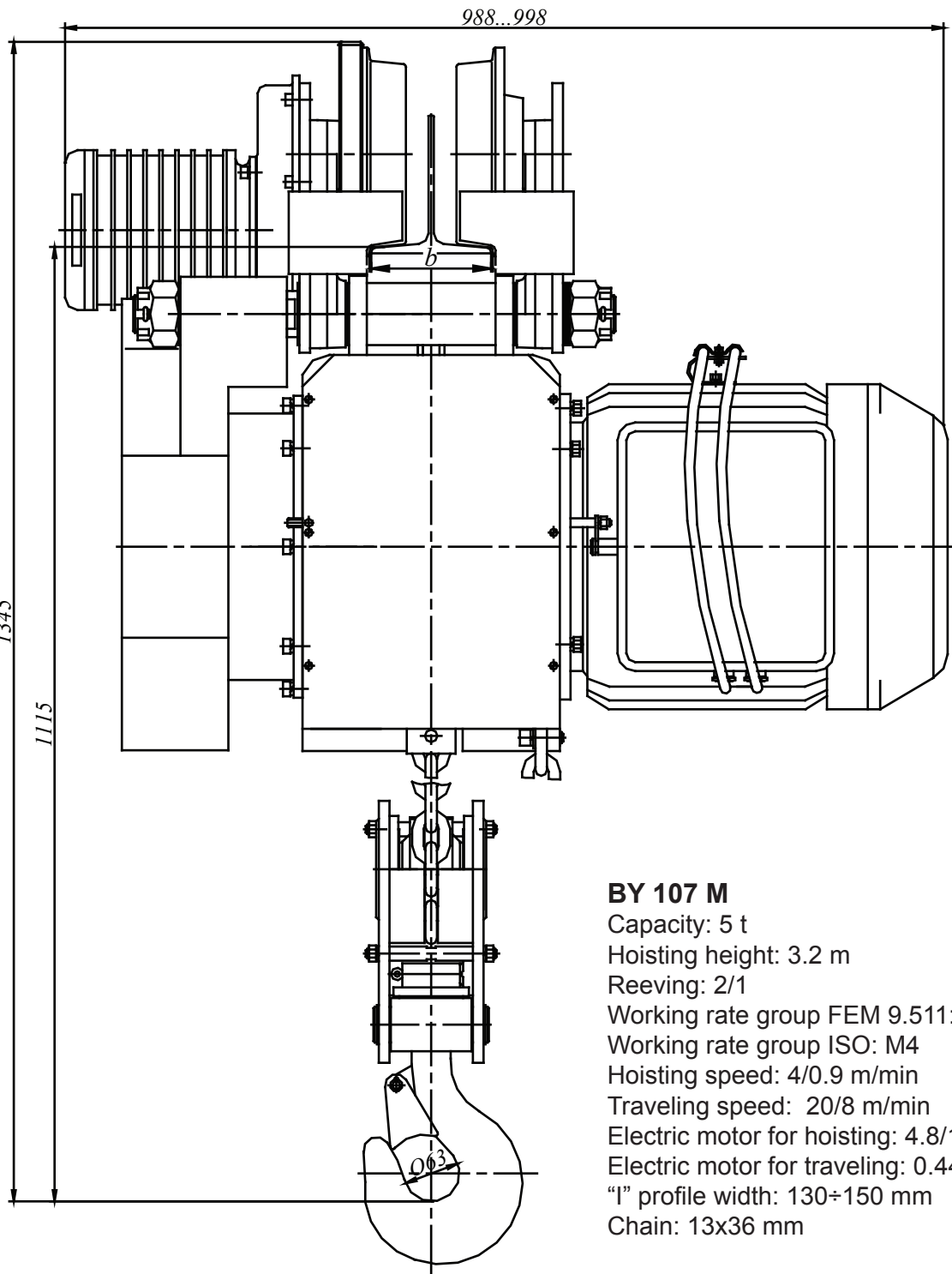

BY 107 M

Capacity: 5 t

Hoisting height: 3.2 m

Reeving: 2/1

Working rate group FEM 9.511: 1Am

Working rate group ISO: M4

Hoisting speed: 4/0.9 m/min

Traveling speed: 20/8 m/min

Electric motor for hoisting: 4.8/1.0 kW

Electric motor for traveling: 0.44/0.12 kW

"I" profile width: 130÷150 mm

Chain: 13x36 mm

