

HYDROSTATIC STEERING UNITS TYPE HKUS.../3, 4, 8

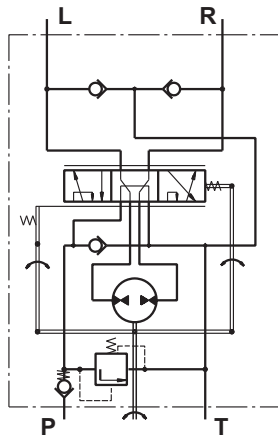

The HKUS Hydrostatic Steering unit is based on the HKU unit but has built-in relief and check valves. Thus Bulmach Sp.z o.o achieves one very compact steering unit which reduces the need for additional hydraulic components in the system.



"Open Center - Load Reaction"
HKUS.../3

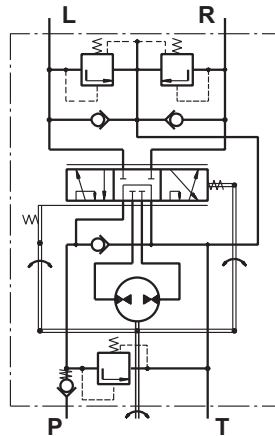

"Open Center - Non Load Reaction"
HKUS.../4

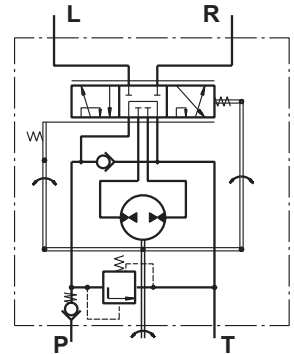

"Open Center - Non Load Reaction"
HKUS.../8

SPECIFICATION DATA

Parameters	Type												
	HKUS 40/3,4,8	HKUS 50/3,4,8	HKUS 63/3,4,8	HKUS 80/3,4,8	HKUS 100/3,4,8	HKUS 125/3,4,8	HKUS 160/3,4,8	HKUS 200/3,4,8	HKUS 250/3,4,8	HKUS 320/3,4,8	HKUS 400/3,4,8	HKUS 500/3,4,8	
Displacement	cm ³ /rev [in ³ /rev]	39,6 [2.42]	49,5 [3.0]	65,6 [4.0]	79,2 [4.83]	99,0 [6.04]	123,8 [7.56]	158,4 [9.67]	198 [12.1]	247,5 [15.1]	316,8 [19.3]	396 [24.2]	495 [30.2]
Rated Flow*	lpm [GPM]	4 [1.1]	5 [1.3]	6 [1.6]	8 [2.1]	10 [2.6]	13 [3.4]	16 [4.2]	20 [5.3]	25 [6.6]	32 [8.4]	40 [10.6]	50 [13.2]
Rated Pressure	bar [PSI]	140 [2030]			170 [2465]								
Relief Valve Pressure		80			100	125	150	170					
Settings**	bar [PSI]	[1160]			[1450]	[1810]	[2175]	[2465]					
Shock Valves Pressure		140			160	180	200	220					
Settings***	bar [PSI]	[2030]			[2320]	[2610]	[2900]	[3190]					
Max. Cont. Pressure in Line T	bar [PSI]	25 [363] (50 [725] by HKUS.../8) 40 [580]											
- standard													
- high pressure (H option)													
Max. Torque at Servoamplifying	Nm [lb-in]	3,0 [26]						3,0 [26]					
- with standard springs		1,8 [16]						-					
- with soft springs (LT option)													
Max. Torque w/o Servoamplifying	Nm [lb-in]	120 [1065]											
Weight	kg [lb]	5,3 [11.7]	5,4 [11.9]	5,5 [12.2]	5,6 [12.4]	5,7 [12.6]	5,8 [12.8]	6,0 [13.2]	6,3 [13.9]	6,5 [14.3]	7,0 [15.4]	7,4 [16.3]	8,0 [17.6]
Dimension A	mm [in]	130,8 [5.15]	132,2 [5.20]	133,9 [5.27]	136,2 [5.36]	138,8 [5.47]	142,2 [5.60]	146,8 [5.78]	152,2 [5.99]	158,8 [6.25]	168,2 [6.62]	178,8 [7.04]	192 [7.56]

* Rated Flow at 100 RPM.

** Pressure Settings are at Rated Flow (as in the table) and viscosity 21 mm²/s [105 SUS] at 50°C [122°F].

*** Pressure Settings are at flow rate of 2 lpm [.53 GPM] and viscosity 21 mm²/s [105 SUS] at 50°C [122°F].

DIMENSIONS AND MOUNTING DATA - HKUS.../3, 4, 8

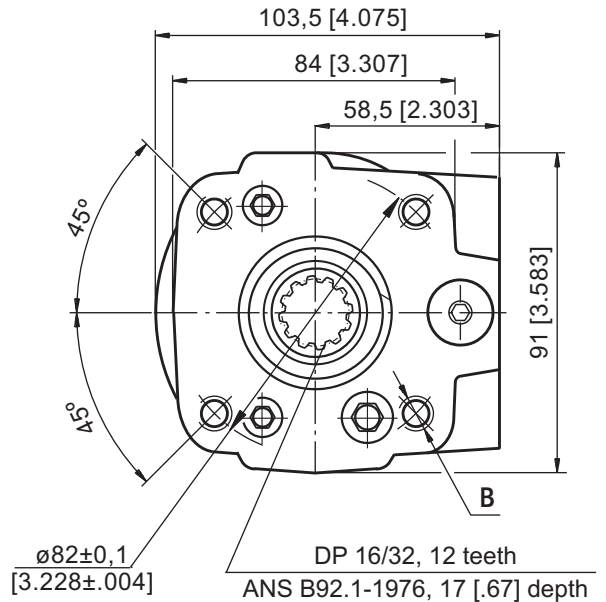
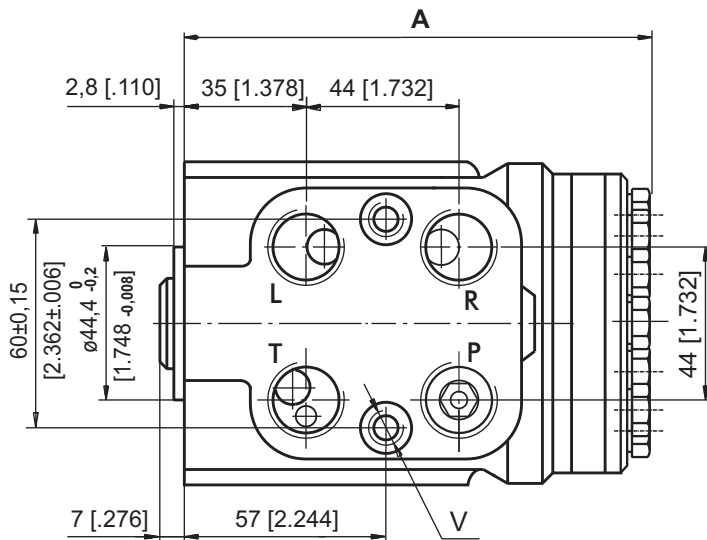

Code	Ports - P*, T, R, L Thread	Column Mounting Thread - B	Valve Mounting Thread - V
-	G1/2 17 [.67] depth	4 x M10 18 [.71] depth	2 x M10x1 16 [.63] depth
M	M22x1,5 17 [.67] depth	4 x M10 18 [.71] depth	2 x M10x1 16 [.63] depth
A	3/4 - 16 UNF O-ring 17 [.67] depth	4 x 3/8 - 16 UNC 15,7 [.62] depth	2 x 3/8 - 24 UNF 14,2 [.56] depth

*Threaded Ports P min 15 [.59] depth for pipe mounting.

STEERING

UNITS

ORDER CODE

	1	2	3	4	5	6	7	8
HKU		/	-					

Pos.1 - Displacement code (see Specification Data)

40	-	39,6	[2.42]	cm ³ /rev	[in ³ /rev]
50	-	49,5	[3.00]	cm ³ /rev	[in ³ /rev]
63	-	65,6	[4.00]	cm ³ /rev	[in ³ /rev]
80	-	79,2	[4.83]	cm ³ /rev	[in ³ /rev]
100	-	99,0	[6.04]	cm ³ /rev	[in ³ /rev]
125	-	123,8	[7.56]	cm ³ /rev	[in ³ /rev]
160	-	158,4	[9.67]	cm ³ /rev	[in ³ /rev]
200	-	198,0	[12.10]	cm ³ /rev	[in ³ /rev]
250	-	247,5	[15.10]	cm ³ /rev	[in ³ /rev]
320	-	316,8	[19.30]	cm ³ /rev	[in ³ /rev]
400	-	396,0	[24.20]	cm ³ /rev	[in ³ /rev]
500	-	495,0	[30.20]	cm ³ /rev	[in ³ /rev]
630	-	623,6	[38.05]	cm ³ /rev	[in ³ /rev]
800	-	793,0	[48.40]	cm ³ /rev	[in ³ /rev]
1000	-	990,0	[60.40]	cm ³ /rev	[in ³ /rev]

Pos.2 - Versions

3	-	Version 3 "Open Center - Load Reaction"
4	-	Version 4 "Open Center - Non Load Reaction"
7	-	Version 7 "Closed Center - Non Load Reaction"

Pos.3 - Ports

omit	-	BSPP (ISO 228)
M	-	Metric (ISO 262)
A	-	SAE (ANSI B 1.1 - 1982)
BA*	-	SAE (ANSI B 1.1 - 1982)

Pos.4 - Max. Cont. Pressure in line T

omit	-	Standard
H	-	High pressure

Pos.5 - Input torque

omit	-	Standard
LT*	-	Low

Pos.6 - Noise level

omit	-	Standard
LN**	-	Low

Pos.7 - Option (Paint)***

omit	-	No Paint
P	-	Painted
PC	-	Corrosion Protected Paint
PS	-	Special Paint****
PCS	-	Special Corrosion Protected Paint****

Pos.8 - Design Series

omit	-	Factory specified
------	---	-------------------

- Notes:** * Available only for displacement from 40 to 200.
 ** Available only for versions 3 and 4 with displacement from 40 to 200.
 *** Colour at customer's request.
 **** Non painted feeding surfaces, colour at customer's request.

The steering units are mangano-phosphatized as standard.

ORDER CODE

	1	2	3	4	5	6	7	8	9
HKUS		/	-	-					

Pos.1 - Displacement code (see Specification Data)

40	-	39,6	[2.42]	cm ³ /rev	[in ³ /rev]
50	-	49,5	[3.00]	cm ³ /rev	[in ³ /rev]
63	-	65,6	[4.00]	cm ³ /rev	[in ³ /rev]
80	-	79,2	[4.83]	cm ³ /rev	[in ³ /rev]
100	-	99,0	[6.04]	cm ³ /rev	[in ³ /rev]
125	-	123,8	[7.56]	cm ³ /rev	[in ³ /rev]
160	-	158,4	[9.67]	cm ³ /rev	[in ³ /rev]
200	-	198,0	[12.10]	cm ³ /rev	[in ³ /rev]
250	-	247,5	[15.10]	cm ³ /rev	[in ³ /rev]
320	-	316,8	[19.30]	cm ³ /rev	[in ³ /rev]
400	-	396,0	[24.20]	cm ³ /rev	[in ³ /rev]
500	-	495,0	[30.20]	cm ³ /rev	[in ³ /rev]

Pos.2 - Versions

3	-	Version 3 "Open Center - Load Reaction"
4	-	Version 4 "Open Center - Non Load Reaction"
8	-	Version 8 "Open Center - Non Load Reaction"

Pos.3 - Relief Valve Pressure Settings, bar

80, 100, 125, 150, 170

Pos.4 - Ports

omit	-	BSPP (ISO 228)
A	-	SAE (ANSI B 1.1 - 1982)
M	-	Metric (ISO 262)

Pos.5 - Max. Cont. Pressure in line T

omit	-	Standard
H	-	High pressure

Pos.6 - Input torque

omit	-	Standard
LT*	-	Low

Pos.7 - Noise level

omit	-	Standard
LN*	-	Low

Pos.8 - Option (Paint)**

omit	-	No Paint
P	-	Painted
PC	-	Corrosion Protected Paint
PS	-	Special Paint***
PCS	-	Special Corrosion Protected Paint****

Pos.9 - Design Series

omit	-	Factory specified
------	---	-------------------

Version	Manual Steering Check Valve	Relief Valve	Inlet Check Valve	Cylinder Relief Valve	Anti-Cavitation Valve
3	•	•	•		•
4	•	•	•	•	•
8	•	•	•		

- Notes:** * Available only for displacement from 40 to 200.
 ** Colour at customer's request.
 *** Non painted feeding surfaces, colour at customer's request.

The steering units are mangano-phosphatized as standard.